

SERVICE VALVES

MULTI-FUNCTION VALVE



MODEL 2500 | **PN 16** | **DN 50 - 2**

Angle type, flanged connection to main feeder DN 50 and female threaded outlet 2"



SPECIAL FEATURES

- Great versatility, usable for multiple purposes: underground hydrant, service valve, on/off venting valve remote operated, access point for network monitoring, etc.
- Manufactured according to the requirements of EN 1074.
- Body and bonnet high quality powder coated (fusion bonded), coating thickness DFT min. 250 micron, zero porosity (tested with 3000V), high impact resistance and cross-linkage according to DIN 30677-2 and DIN 3476
- Multiple O-Ring spindle sealing system embedded in non-corrosive material to DIN 3547-1.
- Additional back sealing disc for O-Rings replacement under pressure to ISO 7259.
- Anti friction bush on spindle neck.
- Non-rising stainless steel spindle (single forged round bar with rolled threading).
- Plug with bottom surfaces fully rubber vulcanised, with drain hole.
- Threads according to EN 10226-1.
- Fasteners protected against corrosion by special resin sealing.
- Manual operation by handwheel, operating cap, extension spindle (underground installation).

MATERIALS

Body and bonnet:

Ductile iron according to EN-GJS-400-15 /EN 1563 (former to DIN GGG40)

Spindle:

Stainless steel 1.4021/EN ISO 10088 (equivalent to UNI X20Cr13 or AISI420)

Plug:

Brass CuZn40Pb2, rubber vulcanised, potable water approved

O-Ring bush:

Brass CuZn40Pb2

Anti-friction bush:

POM

O-Rings, back seal, bonnet seal and dust cap:

Rubber, potable water approved

Fastening screws:

Stainless steel A2-70/EN ISO 3506

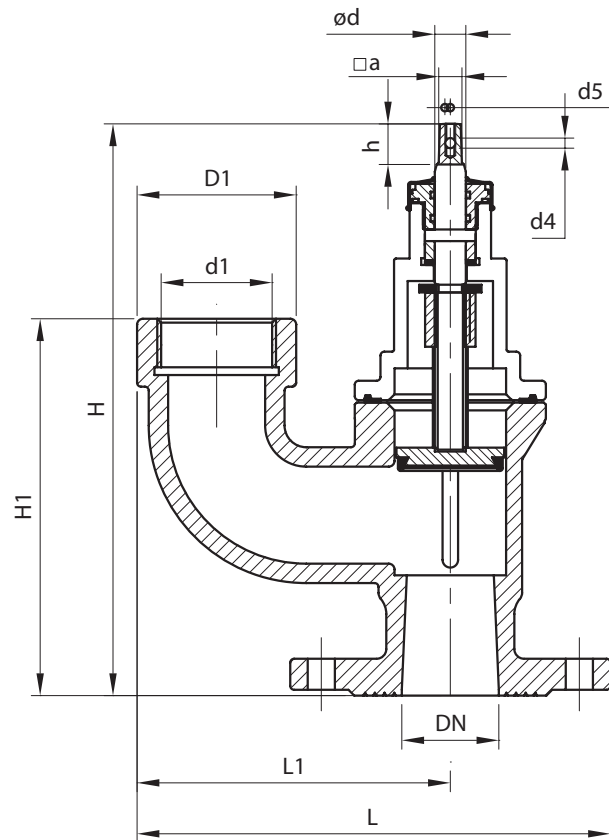

DN	d1	L	L1	H	H1	D1	ød	a	h	d4/d5	weight (kg)
50	2"	244	162	305	194	82	16	10,5-12	26	5/M5	10,5

All metal, rubber, and coatings used have been designed for contact with water for human consumption, pursuant to the terms of Italian Health Ministry decree n° 174, dated 6/4/2004.